

Viega Profipress

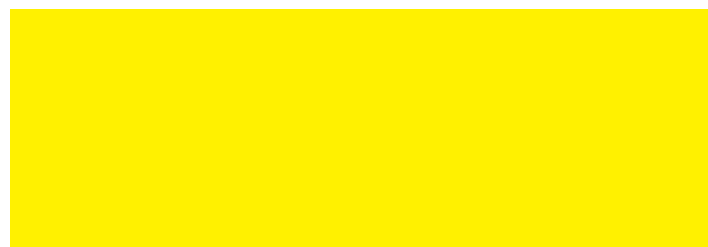

Profipress – lisovací systém neobmedzených možností

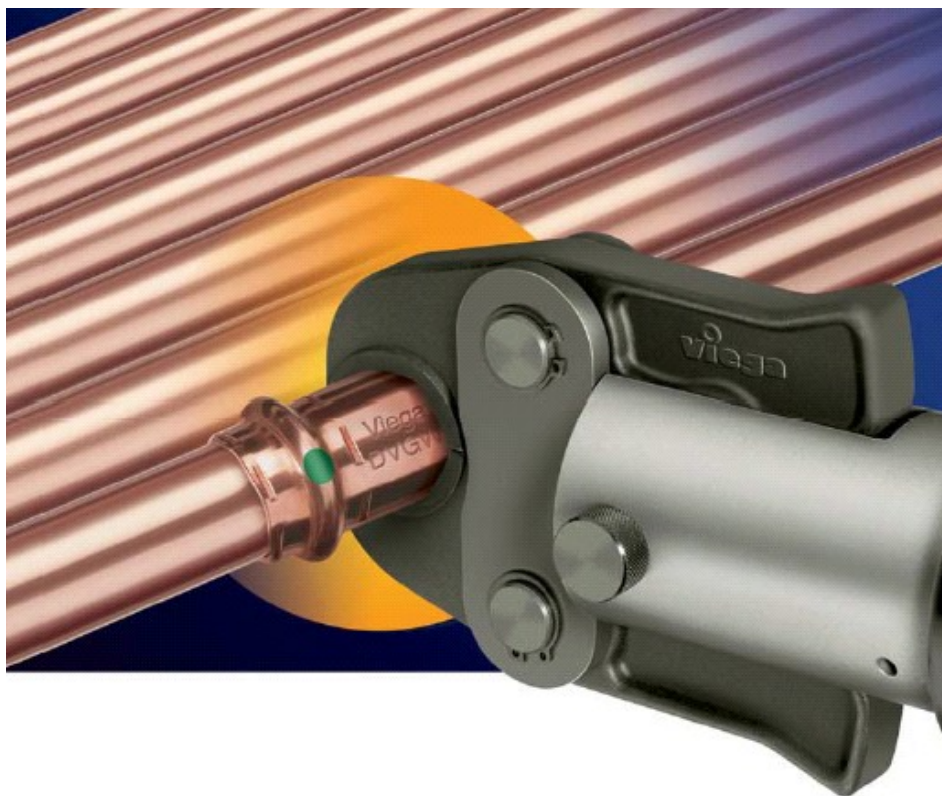

- ▶ jednoduchá montáž
hospodárne a kompletne inštalácie
medených rúrok
- ▶ bezpečný
dvojité lisovanie – záruka 100%
tesnosti a pevnosti spoja
- ▶ časovo nenáročný
v priebehu niekoľko sekúnd je spoj
hotový
- ▶ mnohotvárný
cez 450 tvaroviek s rozmermi 12 až 108mm.

Viega Profipress



Profipress – výrobný sortiment

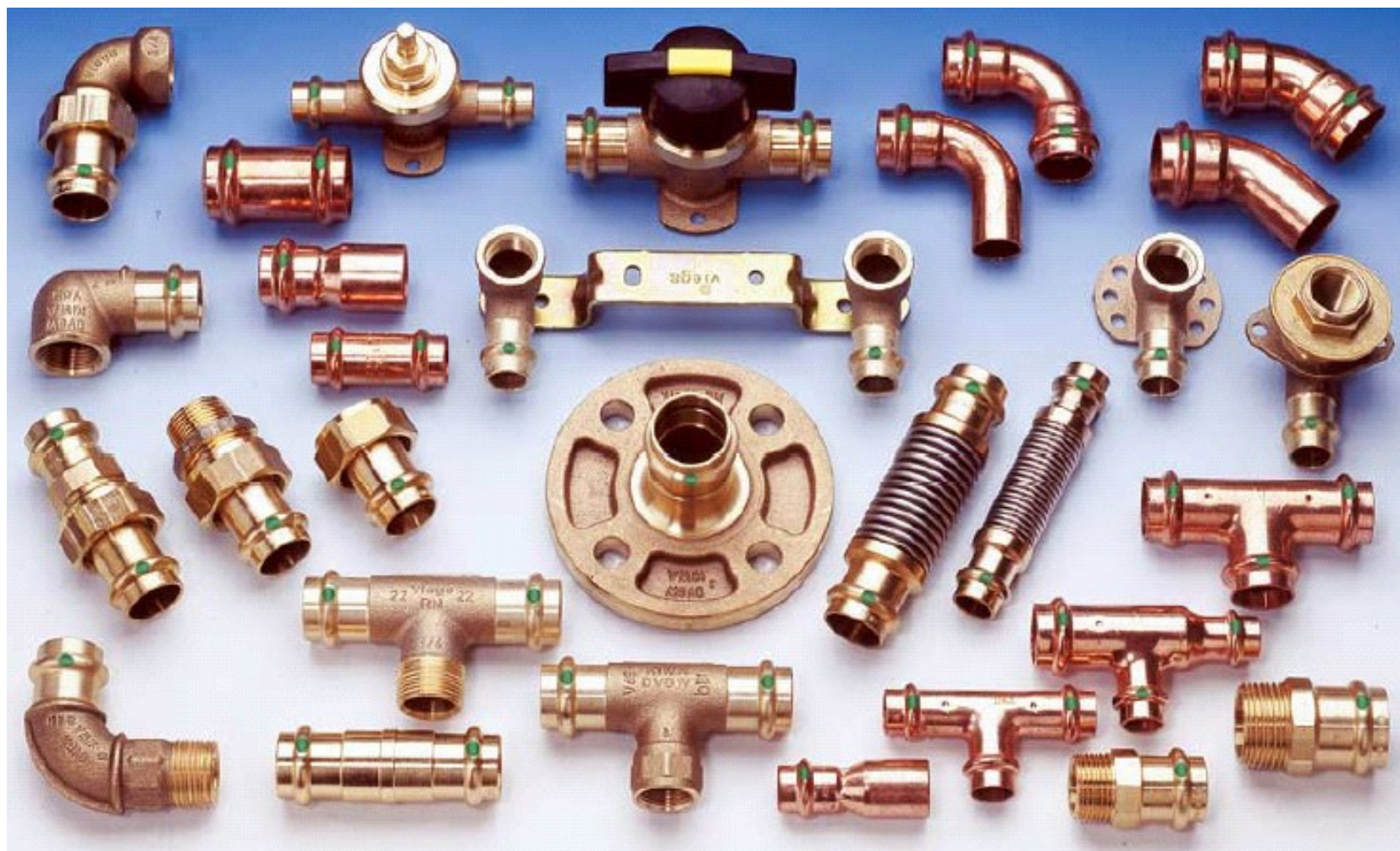

SC Contur – znamienko istoty lisovaného spoja



- ▶ Dvojité zlisovanie
Zlisovanie pred a za tesniacim krúžkom –
dvojnásobná istota pre zachytenie maximálnych síl
- ▶ Tesniaci element z EPDM
EPDM – Etylen – Propylen – Dien – kaučuk
Farba: čierna
Životnosť nad 50 rokov
- ▶ SC – Contur (Sicherheits-Contur)
Istota pre tlakové skúšky
- ▶ Válcové vedenie pre tesnením
Proti poškodeniu tesniaceho krúžku



SC Contur s viditeľnou kontrolou zalisovania



Profipress s SC-Contur:
nezlisované = pri tlakovej skúške
viditeľne netesné

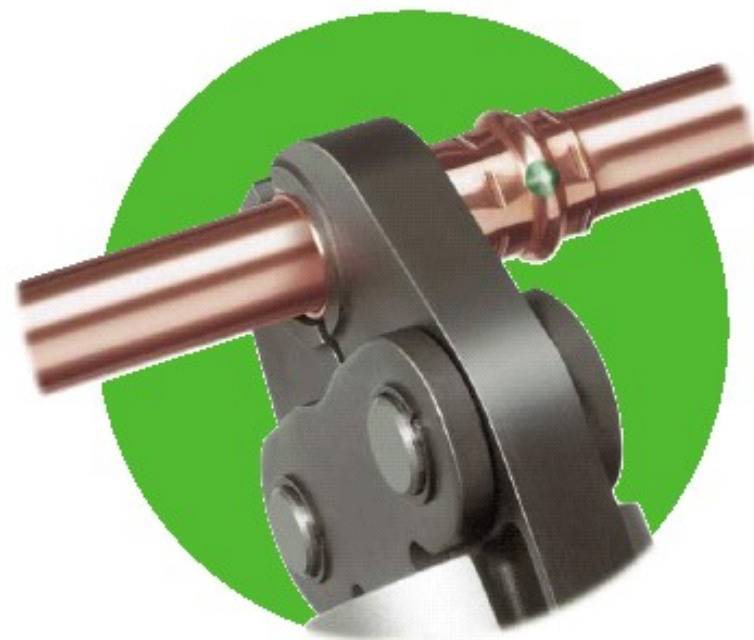

Profipress s SC-Contur:
zlisované = zaručene tesné

Vonkajší priemer a hrúbka medených rúrok, ...

Vonkajší priemer Ø [mm]	hrúbka steny potrubia (mm)									
	0,6	0,7	0,8	0,9	1,0	1,1	1,2	1,5	2,0	2,5
12	•	•	•		•					
15		•	•		•		•	•		
18			•		•		•	•		
22				•	•	•	•	•		
28				•	•		•	•		
35						•	•	•	•	
42						•		•	•	
54								•	•	•
76,1										•
88,9										•
108										

podľa DIN EN 1057, s ktorými Viega Profipress – Systém môžete lisovať

Minimálne vzdialenosti medzi 2 zlisovanými spojmi

dimenzia	predtým	teraz
12 mm	10 mm	0 mm
15 mm	10 mm	0 mm
18 mm	15 mm	0 mm
22 mm	20 mm	0 mm
28 mm	20 mm	0 mm
35 mm	25 mm	10 mm
42 mm	30 mm	15 mm
54 mm	35 mm	25 mm

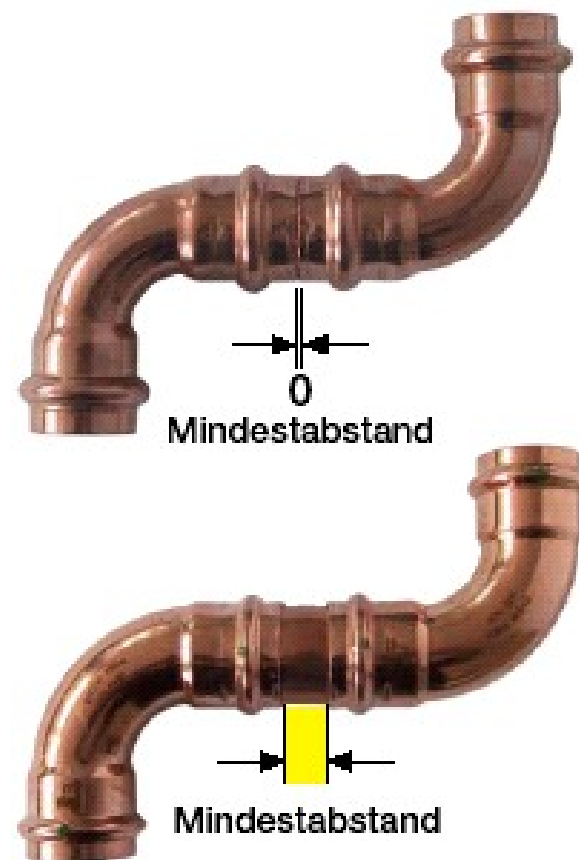

Platí rovnako pre Profipress ako aj Profipress Gas

Montážny návod

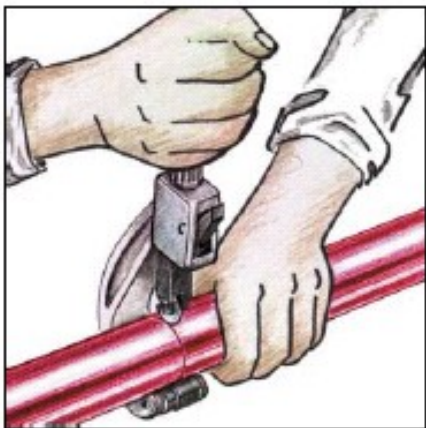

1

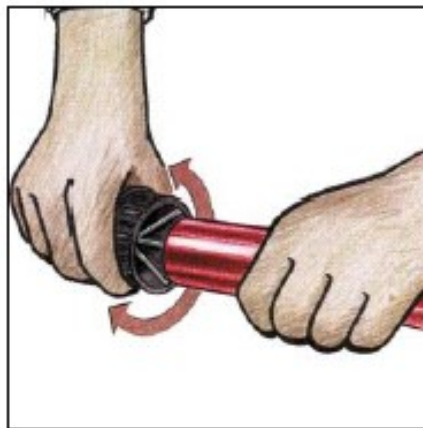

2

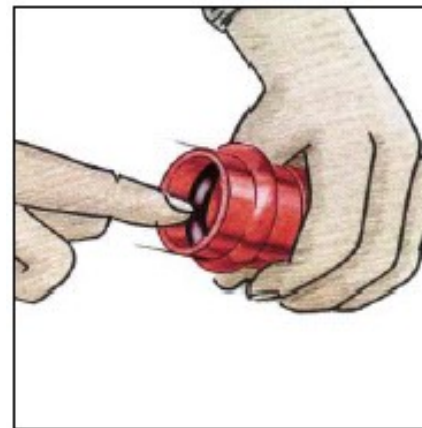

3

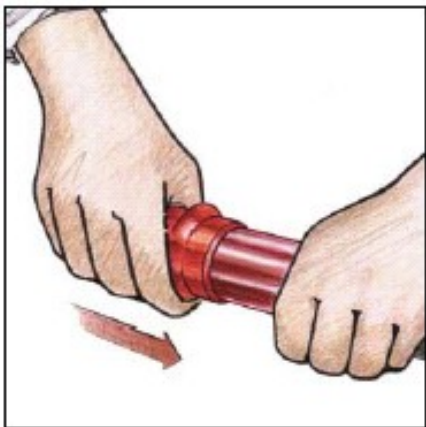

4

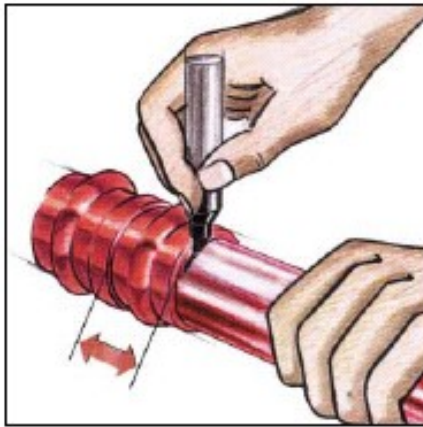

5

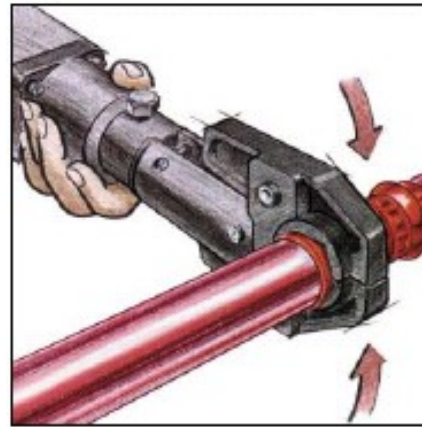

6

Viega Profipress



Profipress v praxi



Viega Profipress



Profipress v praxi



Viega Profipress XL



Profipress XL – Dimenzia > DN50

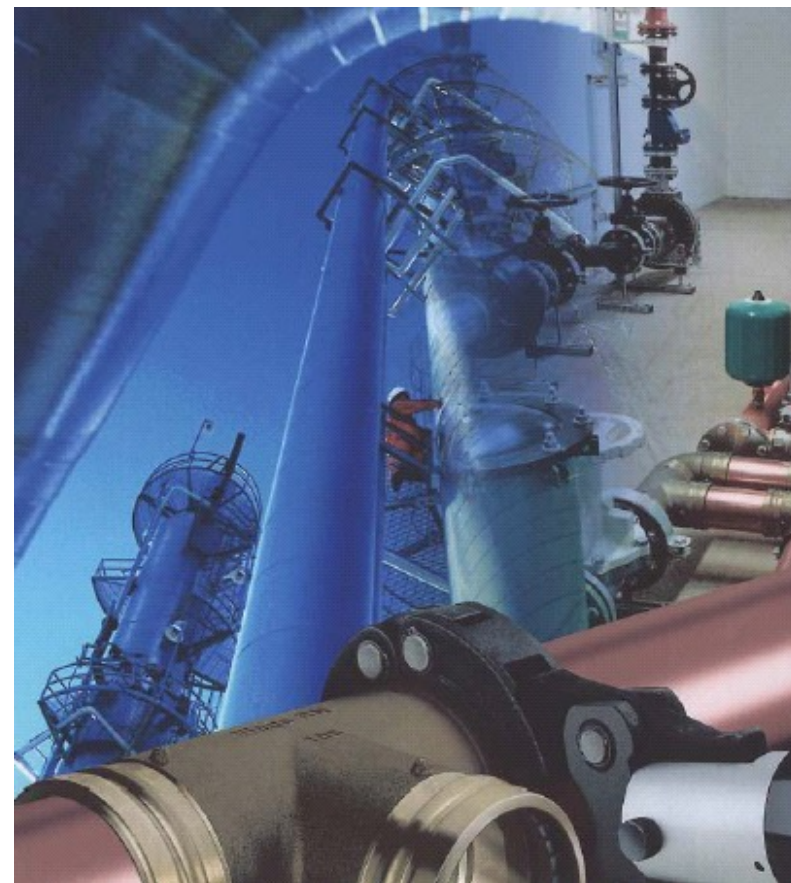
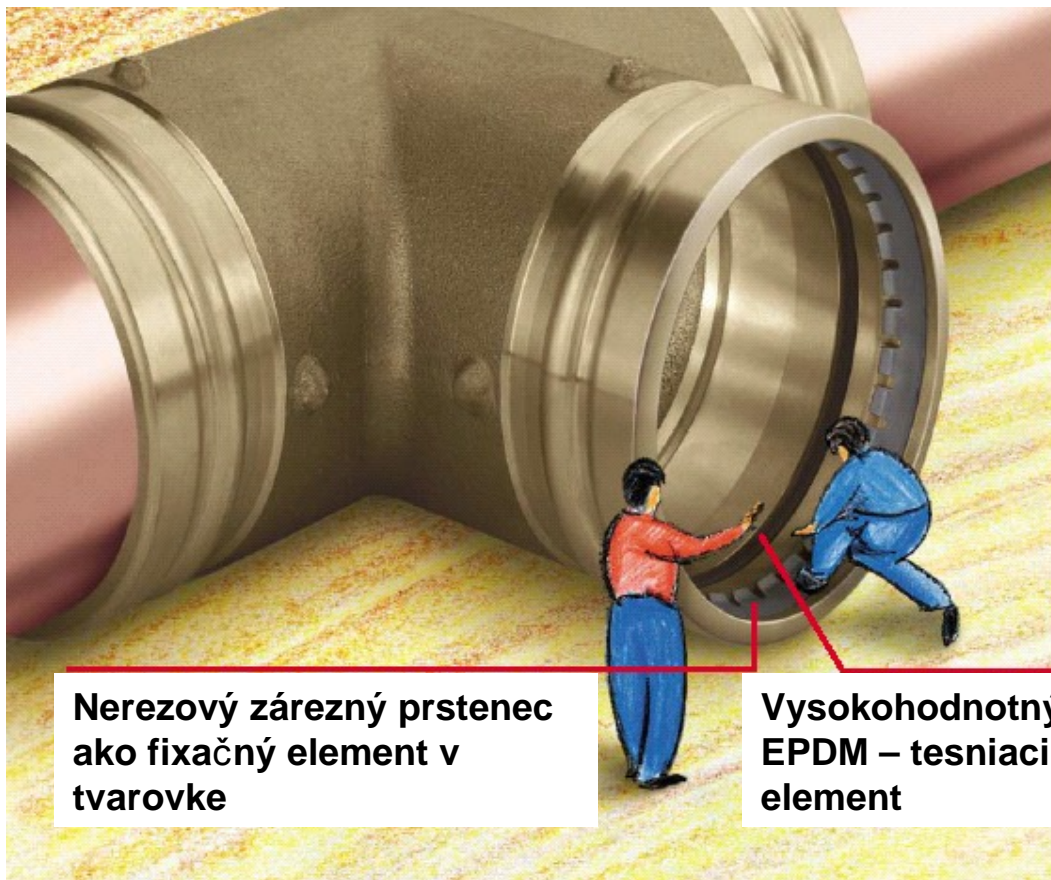

Viega Profipress XL



Minimálne vzdialenosti medzi 2 zlisovanými spojmi

DN 65 DN 80 DN 100

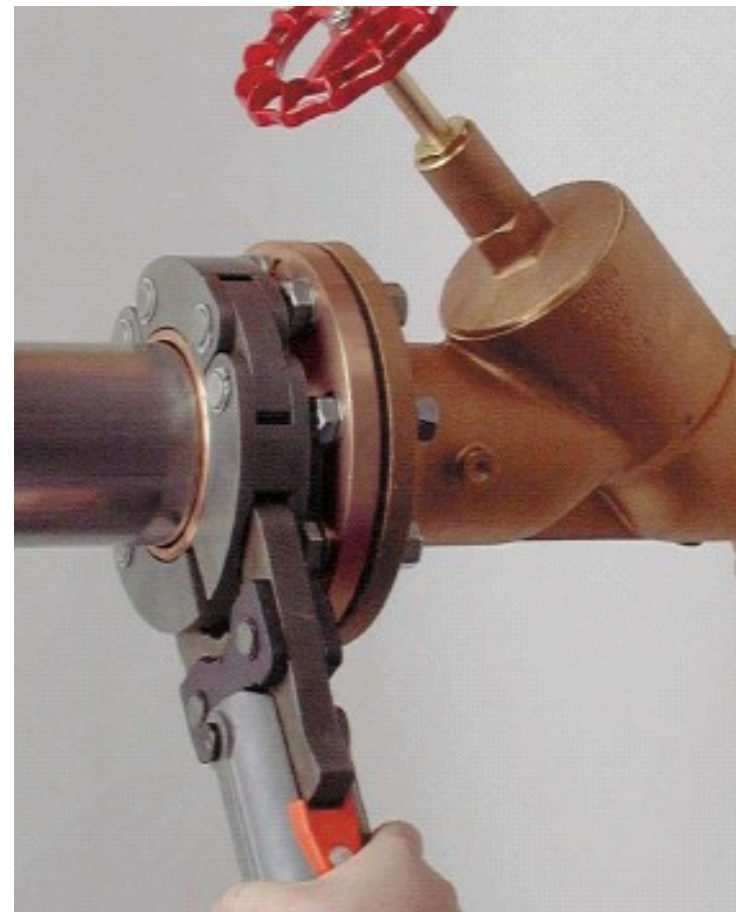
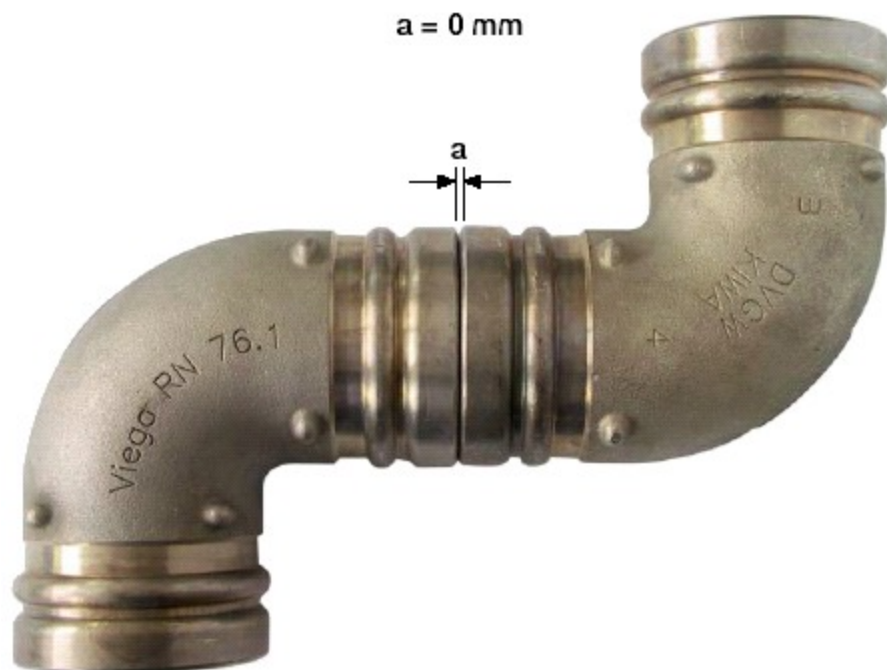

Viega Profipress XL



Montážny návod pre Profipress XL

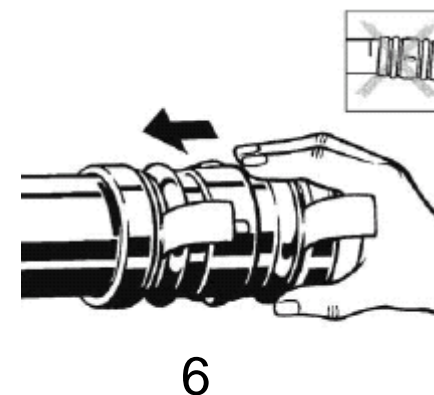
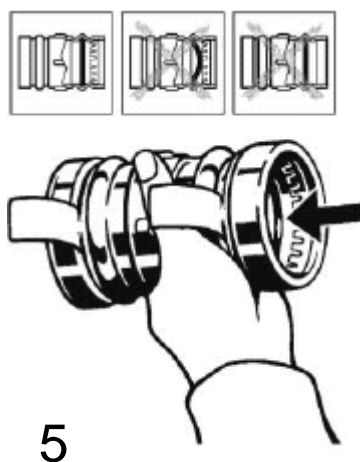
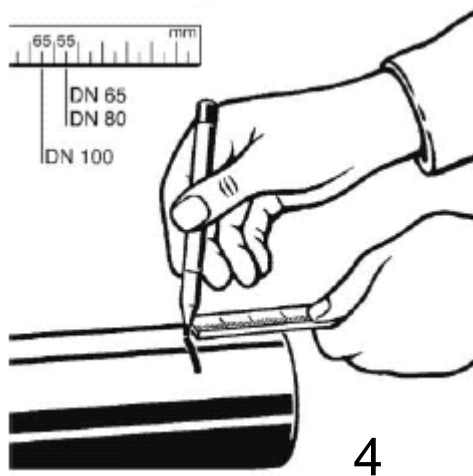
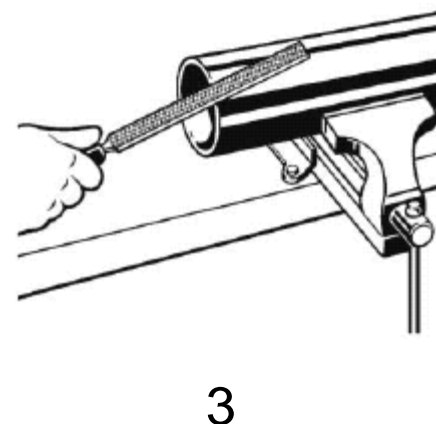
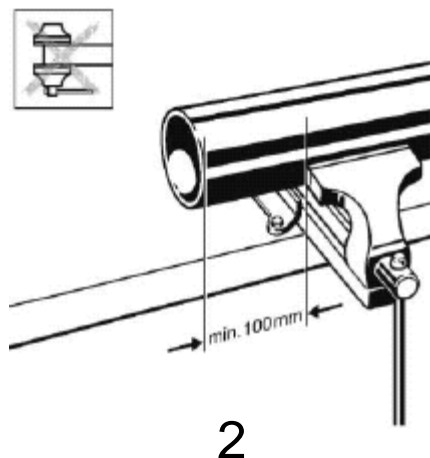
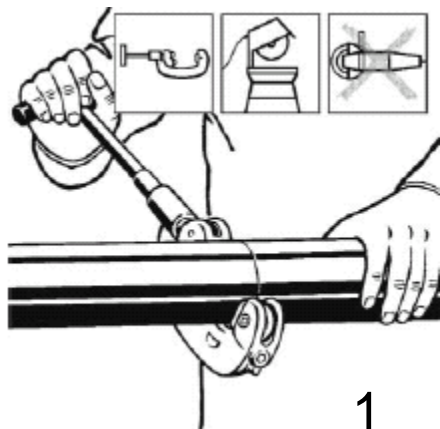

Viega Profipress XL



Montážny návod pre Profipress XL

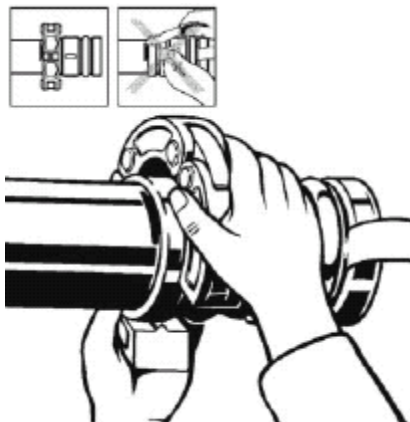

7

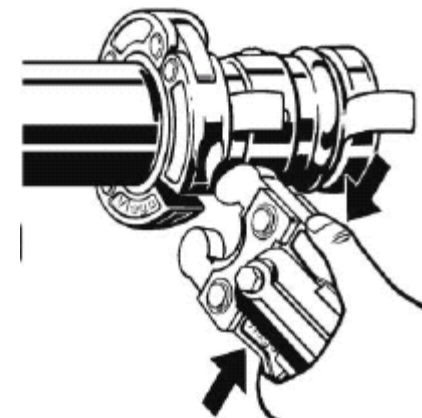

8

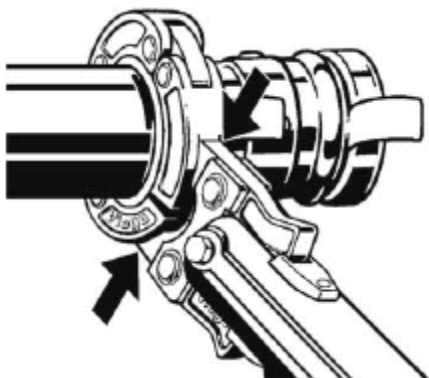

9

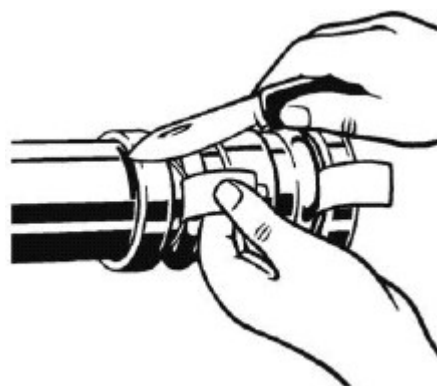

10

Viega Profipress XL

viega

Lisovacie elektrohydraulické náradie



Typ: 3 - EH 230 V



Typ: 3 - AH



Lisovacie čeluste
pre dimenzie:

12, 15, 18, 22, 28,
35, 42, 54mm

Lisovacia reťaz +
ťahná čelusť:

76,1mm
88,9mm
108,0mm